



900 MHz Spread Spectrum
**Switch Follower/Voltage Input
Transmitter**

Models:
SF900C4-B-B
SF900C8-B-B

900 MHz Spread Spectrum
**Switch Follower/Voltage Input
Receiver**

Models:
SF900C4-B-R
SF900C8-B-R



900 MHz Spread Spectrum
**Switch Follower/Voltage Input
Transmitter- Outdoor**

Models:
SF900C4-B-B-OPT14
SF900C8-B-B-OPT14

900 MHz Spread Spectrum
**Switch Follower/Voltage Input
Receiver- Outdoor**

Models:
SF900C4-B-R-OPT14
SF900C8-B-R-OPT14



Models: SF900C Series

FCC ID: QY4-618

"This device complies with Part 15 of the FCC Rules. Operation is subject to the following two conditions: (1) this device may not cause harmful interference, and (2) this device must accept any interference received, including interference that may cause undesired operation."

INSTRUCTION TO THE USER

Note: This equipment has been tested and found to comply with the limits for a Class B digital device, pursuant to part 15 of the FCC Rules. These limits are designed to provide reasonable protection against harmful interference in a residential installation. This equipment generates, uses and can radiate radio frequency energy and, if not installed and used in accordance with the instructions, may cause harmful interference to radio communications. However, there is no guarantee that interference will not occur in a particular installation. If this equipment does cause harmful interference to radio or television reception, which can be determined by turning the equipment off and on, the user is encouraged to try to correct the interference by one or more of the following measures:

- Connect the equipment into an outlet on a circuit different from that to which the receiver is connected.
- Consult an experienced radio/TV technician for help.

Changes or modifications not expressly approved by *Applied Wireless* could void the user's authority to operate the equipment.

Applied Wireless Inc.

Switch Follower/Voltage Input Wireless Control Model SF900C4 or SF900C8

Product Descriptions

The SF900C Series switch followers are a two-way system designed to provide a quick and cost effective solution for a variety of wireless switching applications. Each unit has 4 or 8 inputs connected to a transmitter and 4 or 8 10 Amp SPDT relay outputs connected to a receiver. They are transceivers designed to work in pairs, the output relays at the *far* unit will “follow” the inputs at the *near* unit and vice versa.

For the SF900C Pair, an optional *loopback* mode can be wired for each channel separately. At the RECEIVE end the relay output can be wired to activate the units corresponding input. This will close the corresponding relay at the originating TRANSMIT end confirming the switch change was carried out at the RECEIVE end.

The inputs are opto-isolated and may be operated by an applied voltage that can be supplied by a power source from 5 to 24 Volts AC or DC through a switch contact, relay, sensor, PLC output, etc.

These products utilize frequency hopping spread spectrum technology and are immune to interference and multipath fading. All inputs and outputs are independently isolated from each other and from the power supply and ground. Expected range with these products is 3 miles*. The receiver requires 12 to 24 Volts AC or DC (supply not included).

* Unobstructed, straight line-of-sight range, when used with the standard antennas included with the SF900C pair.

Features

- Voltage/Dry Contact Inputs
- 4-Input or 8-Input Models
- 10A Relay Outputs
- Long Range: Up to 3-miles
- 2-Way Operation
- Multiple Receivers Can Be Used With Single Transmitter
- Loopback Mode sends Acknowledgement back to Transmit Side
- Spread Spectrum Technology
- 12-24 Volt DC or AC Operation
- 120/240 VAC Power Input Option
- NEMA 4X Enclosure Option
- Antenna Included
- FCC Certified
- Made in USA

Typical Applications

- Pump Control
- Motor Control
- Solenoid Control
- Lighting Control
- Access Control
- PLC Activation
- HVAC Control
- Conveyer Control

LED Indicators (Receiver)

Power LED: Indicates that voltage is applied to the receiver.

Learn LED: LED blinks when in the learn mode.

Relay LED's : They indicate for each relay whether the relay is activated.

Data LED: LED indicates reception of RF signal at the receivers frequency of operation. For troubleshooting purposes, it can indicate the following:

- 1) Whether the transmitter is actually transmitting.
- 2) Whether there are interfering signals at the receiver's frequency of operation. The LED should be dim if the transmitter has no input activated or button is not being pressed. Any LED indication would indicate that an interfering signal is present, the severity of which is indicated by how much the LED is activated.

Installation Instructions

Before Beginning the Installation

Plan your installation carefully. The physical location and orientation of the unit will have an influence on reception, particularly at longest ranges. For best results, **the antennas should be positioned vertically (pointing either up or down)**. If necessary, use double-sided foam tape or hook & loop fasteners (not supplied) to secure the unit to a non-metallic *vertical* surface. Also, keep in mind that the RF signal from these spread spectrum products will travel through most non-metallic building materials (wood, stucco, brick, etc.), however maximum stated reception range is based on unobstructed line of sight conditions. Antenna extension cables are available when necessary to optimize antenna placement for range considerations.

POWER HOOKUP

The SF900C receiver has an internal DC/DC converter, so it may be connected to either 12-24 VDC or 12-24 VAC. The rightmost upper and lower terminals are for power. When using DC, the polarity is not important.

The SF900C-OPT14 outdoor models are also available with optional 124/240VAC internal power supply.

MULTIPLE RECEIVERS TO ONE TRANSMITTER HOOKUP

If multiple receivers are used in a system, ACKNOWLEDGMENT must be disabled in all but one receiver. If this is not done, the transmitter will have multiple transmissions coming back at it at the same time, essentially jammy it. This is an internal jumper setting tht the installer can do, or the factory can do.

Multiple transmitters to one or more receivers will not work.

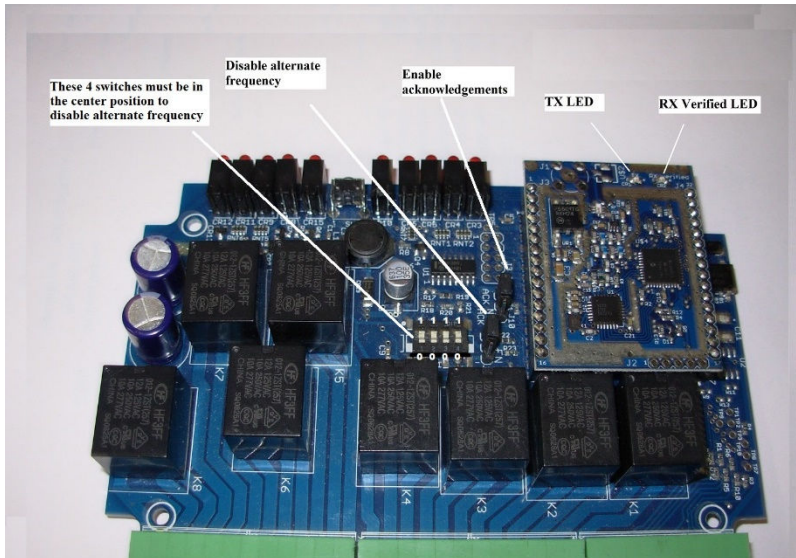

LEARN PROCEDURE

STANDARD TWO WAY APPLICATION: To pair two SF900C units, place both units in the learn mode by pushing their respective learn buttons. The learn lights will flash. Let's call one the Base unit and the other the Remote unit. The second push of the learn button on the Remote unit will trigger the learning process. Once completed, the learn lights will turn Off. The Remote unit will have learned and adopted the code and frequency of the Base unit. The Base unit is defined as the unit that has not adopted an alternate code. The distinction is important for the next example.

More SF900C receivers can be added to the above system one at a time by using the same SF900C as the Base unit. However, the covers will have to be removed from the additional SF900C receivers and the ACK jumper will have to be moved to the NO ACK position to disable acknowledgements. When a signal is received from a transmitter, only one receiver, logically the Base unit, must reply with an acknowledgment to avoid collisions.



CHANGING THE FREQUENCY

It is rarely necessary to change the frequency, however the following outlines the procedure should it be necessary:

The least significant 5 bits of the address of the Base unit is used to determine the frequency of operation, one of 32 possible. Therefore, there is a 1 in 32 chance that any two units will be operating on the same frequency. The label on the units will have the 4-digit hex code as well as a 2-digit hex frequency. If two or more Base units are to be operating in the same area and they have the frequency, the Base units can be set to different frequencies.

Use the 4-position dip switch covering switch positions 2 - 5 and an enable jumper in place of switch 6 allowing for 16 possible frequencies. To enable the alternate frequency selection, Jumper J4 must be moved to the two pins closest to the "EN" position

and each of the dip switches must be moved up or down. To disable the alternate frequency selection, the enable jumper must be moved to the two pins farthest from the EN location and the dip switches must be moved to the center tri-state position. See the Frequency Select Switch Table. (1 is UP and 0 is DOWN.)

NOTE: Whenever the frequency select switch, S1, is changed on the Base unit, the power has to be turned Off and back On again for the frequency change to take effect. Then, the Learn Procedure will have to be repeated for all of the Remote units associated with the Base unit that has a new frequency setting.

FREQUENCY TABLE

CHANNEL	CHANNEL	6 Position Switch	4 Position Switch
<u>Decimal</u>	<u>HEX</u>	<u>BINARY, lsb first</u>	<u>BINARY, lsb first</u>
0	00	000000	0000 EN
1	01	100000	
2	02	010000	1000 EN
3	03	110000	
4	04	001000	0100 EN
5	05	101000	
6	06	011000	1100 EN
7	07	111000	
8	08	000100	0010 EN
9	09	100100	
10	0A	010100	1010 EN
11	0B	110100	
12	0C	001100	0110 EN
13	0D	101100	
14	0E	011100	1110 EN
15	0F	111100	
16	10	000010	0001 EN
17	11	100010	
18	12	010010	1001 EN
19	13	110010	
20	14	001010	0101 EN
21	15	101010	
22	16	011010	1101 EN
23	17	111010	
24	18	000110	0011 EN
25	19	100110	
26	1A	010110	1011 EN
27	1B	110110	
28	1C	001110	0111 EN
29	1D	101110	
30	1E	011110	1111 EN
31	1F	111110	

ELECTRICAL CHARACTERISTICS

Sym	Parameter	Min	Typ	Max	Unit
	Operating Voltage Range	10	12	36	Volts
	Operating Current, Receive Mode		45	56	mA
	Operating Current, Transmit Mode		212	225	mA
	Input Resistance		4.7K		Ohms
	Signal Input Voltage	5		28	Volts AC or DC
	Output Relay Contact Ratings at 28VDC			10	Amps
f	Frequency Range	902		928	MHz
P _{out}	Output Power		15		mW
Z _{out}	Antenna Input Impedance		50		Ohms
T _{op}	Operating Temperature	-20		+60	C

ORDERING INFORMATION

Transmitters (Base Units)

Model No.	Product Description	Channels/ Buttons	Range	Response Time
SF900C4-B-B	Switch Follower Transmitter	4	3-miles	180 ms
SF900C4-J-B	Switch Follower Transmitter	4	½-Mile	58 ms
SF900C8-B-B	Switch Follower Transmitter	8	3-miles	180 ms
SF900C8-J-B	Switch Follower Transmitter	8	½-Mile	58 ms
Outdoor Units				
SF900C4-B-B-OPT14	Switch Follower/Voltage Input Transmitter, NEMA 4X Enclosure	4	3-miles	180 ms
SF900C4-J-B-OPT14	Switch Follower/Voltage Input Transmitter, NEMA 4X Enclosure	4	½-Mile	58 ms
SF900C8-B-B-OPT14	Switch Follower/Voltage Input Transmitter, NEMA 4X Enclosure	8	3-miles	180 ms
SF900C8-J-B-OPT14	Switch Follower/Voltage Input Transmitter, NEMA 4X Enclosure	8	½-Mile	58 ms
Suffix -PS to any OPT14 Model	120/240VAC Input			

Receivers

Model No.	Product Description	Channels/ Buttons	Range	Response Time
SF900C4-B-R	Switch Follower Receiver	4	3-miles	180 ms
SF900C4-J-R	Switch Follower Receiver	4	½-Mile	58 ms
SF900C8-B-R	Switch Follower Receiver	8	3-miles	180 ms
SF900C8-J-R	Switch Follower Receiver	8	½-Mile	58 ms
Outdoor Units				
SF900C4-B-B-OPT14	Switch Follower Receiver, NEMA 4X Enclosure	4	3-miles	180 ms
SF900C4-J-B-OPT14	Switch Follower Receiver, NEMA 4X Enclosure	4	½-Mile	58 ms
SF900C8-B-B-OPT14	Switch Follower Receiver, NEMA 4X Enclosure	8	3-miles	180 ms
SF900C8-J-B-OPT14	Switch Follower Receiver, NEMA 4X Enclosure	8	½-Mile	58 ms
Suffix -PS to any OPT14 Model	120/240VAC Input			

Related Optional Products

Model	Description	Volts	Current
610442-SAT	AC Power Adapter, 120VAC Input	12 V _{DC}	500 mA
610347	AC Power Adapter, 120VAC Input	24 V _{DC}	800 mA
610300	AC Power Transformer, 120VAC Input	24 V _{AC}	20 VA
269006	AC Power Line Contactor, SPST, 30A, 24VAC coil	240VAC	30A

Optional Antenna Bulkhead Extension Cables

Model	Description	Length
600279-8	RPSMA Male to Female	8 Inches
600279-L100E-24	LMR-100 or Equiv.	24 Inches
600279-10F-L200	LMR-200 or Equiv.	10-Ft

600279-15F-L200	LMR-200 or Equiv.	15-Ft
600279-20F-L200	LMR-200 or Equiv.	20-Ft
600279-25F-L200	LMR-200 or Equiv.	25-Ft
Other lengths available		

BLOCK DIAGRAM

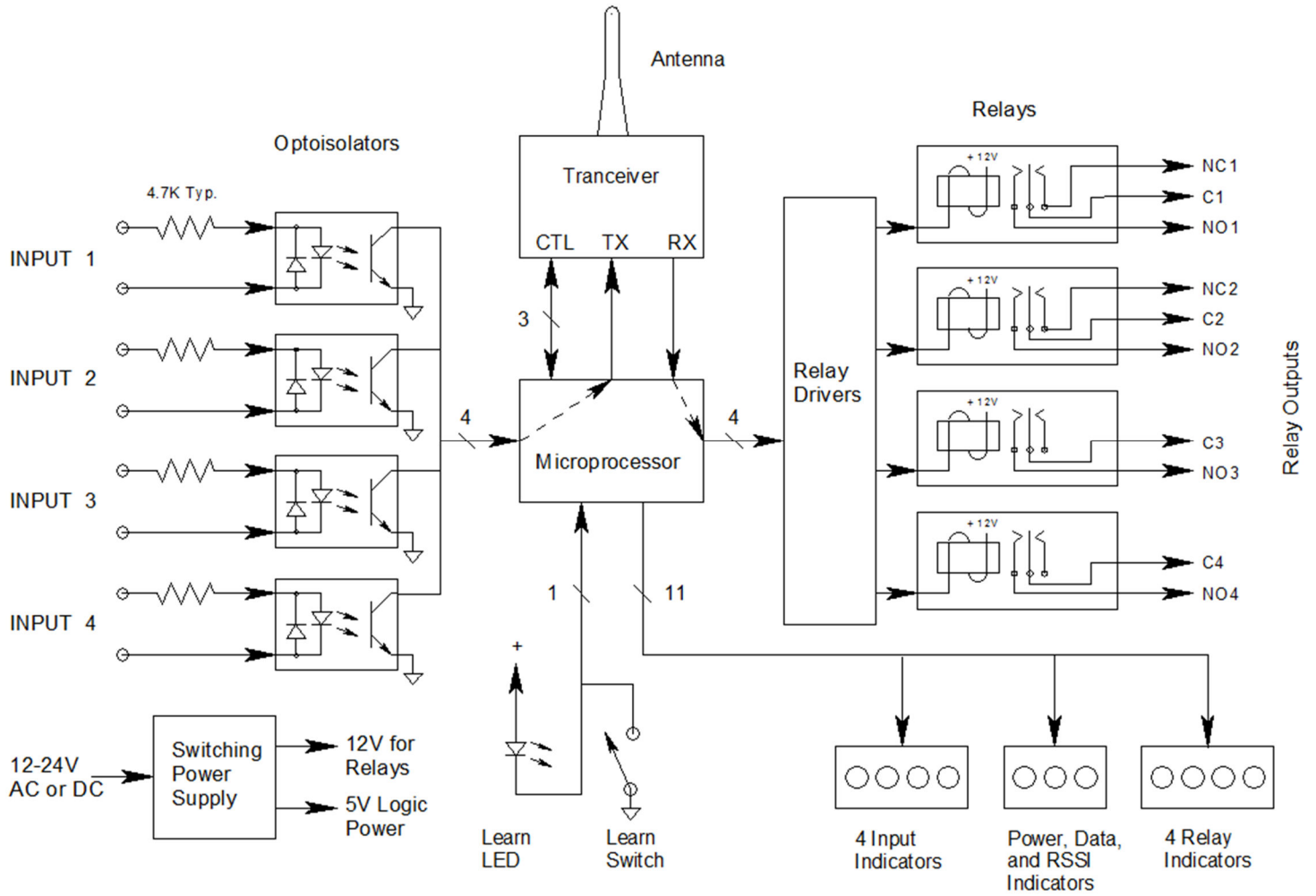

RECEIVER PACKAGE DIMENSIONS

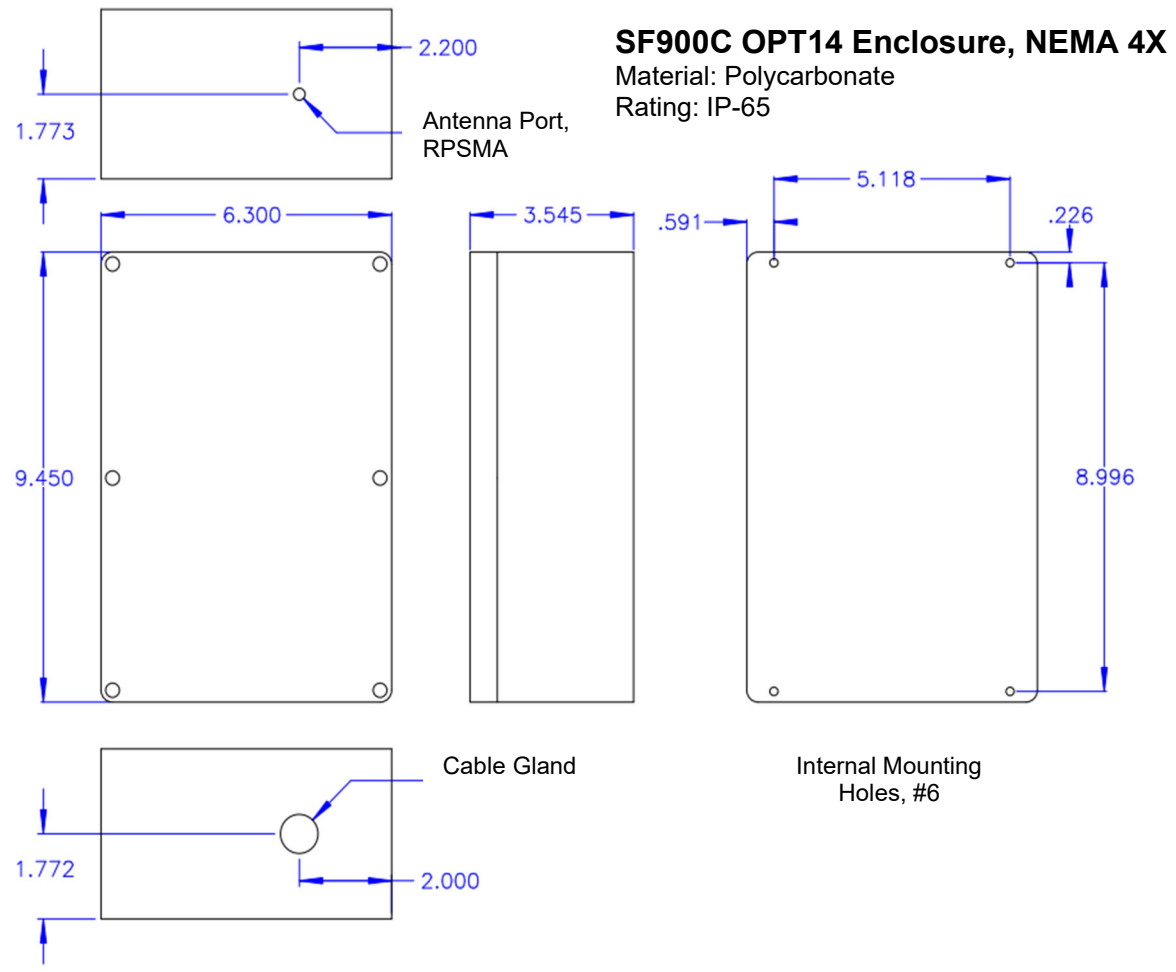
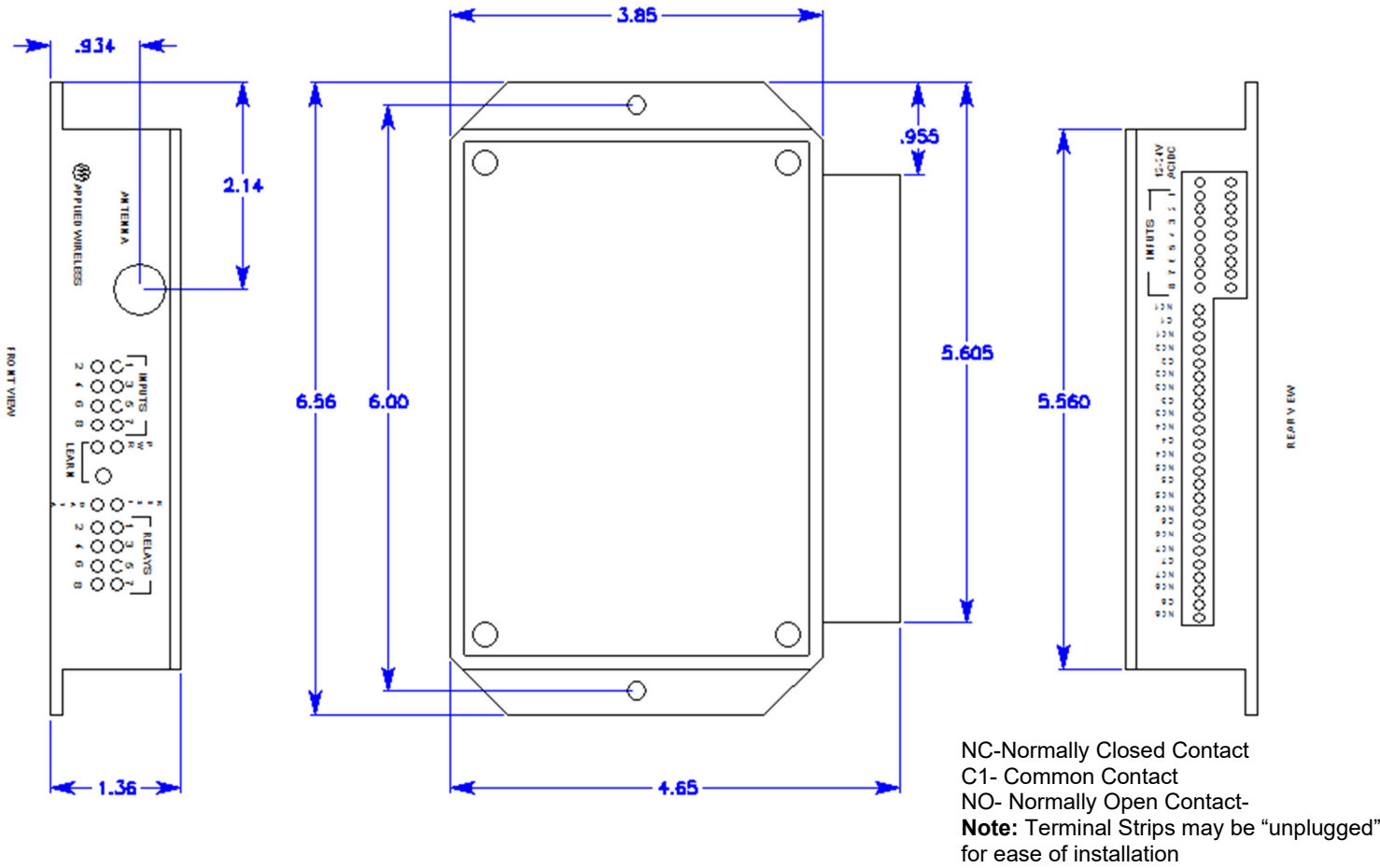

APPLICATION DIAGRAMS

Remote Activation of Relay(s)

In this example, switch(s) activation on a water tank or other switch application, will remotely activate a relay(s) for activating, pump, motor, light or other device.

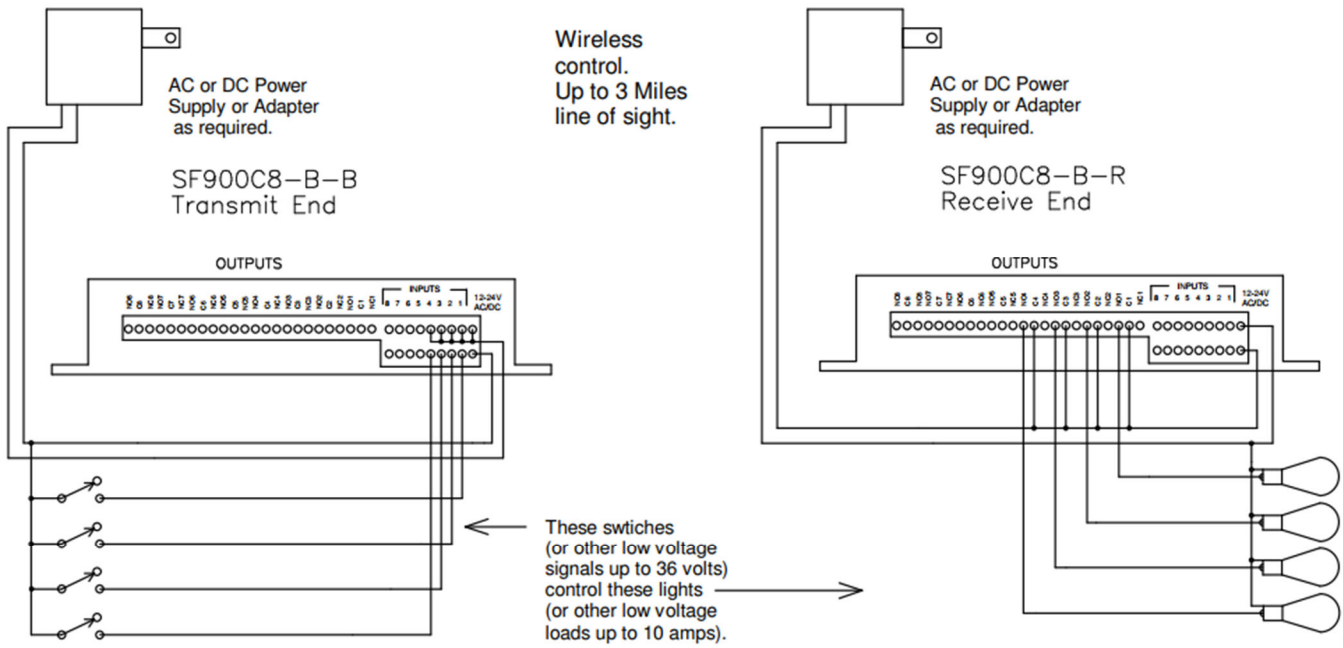

APPLIED WIRELESS
SF900C
Standard One Way Application
4 of 8 circuits shown

APPLICATION DIAGRAM

Acknowledgement / Loopback

In loopback mode, the target relay(s) is/are activated as in the earlier example. However, in Loopback mode, a transmission will then be sent back to the originating location and a relay(s) activated as feedback that the remote operation has been carried out.

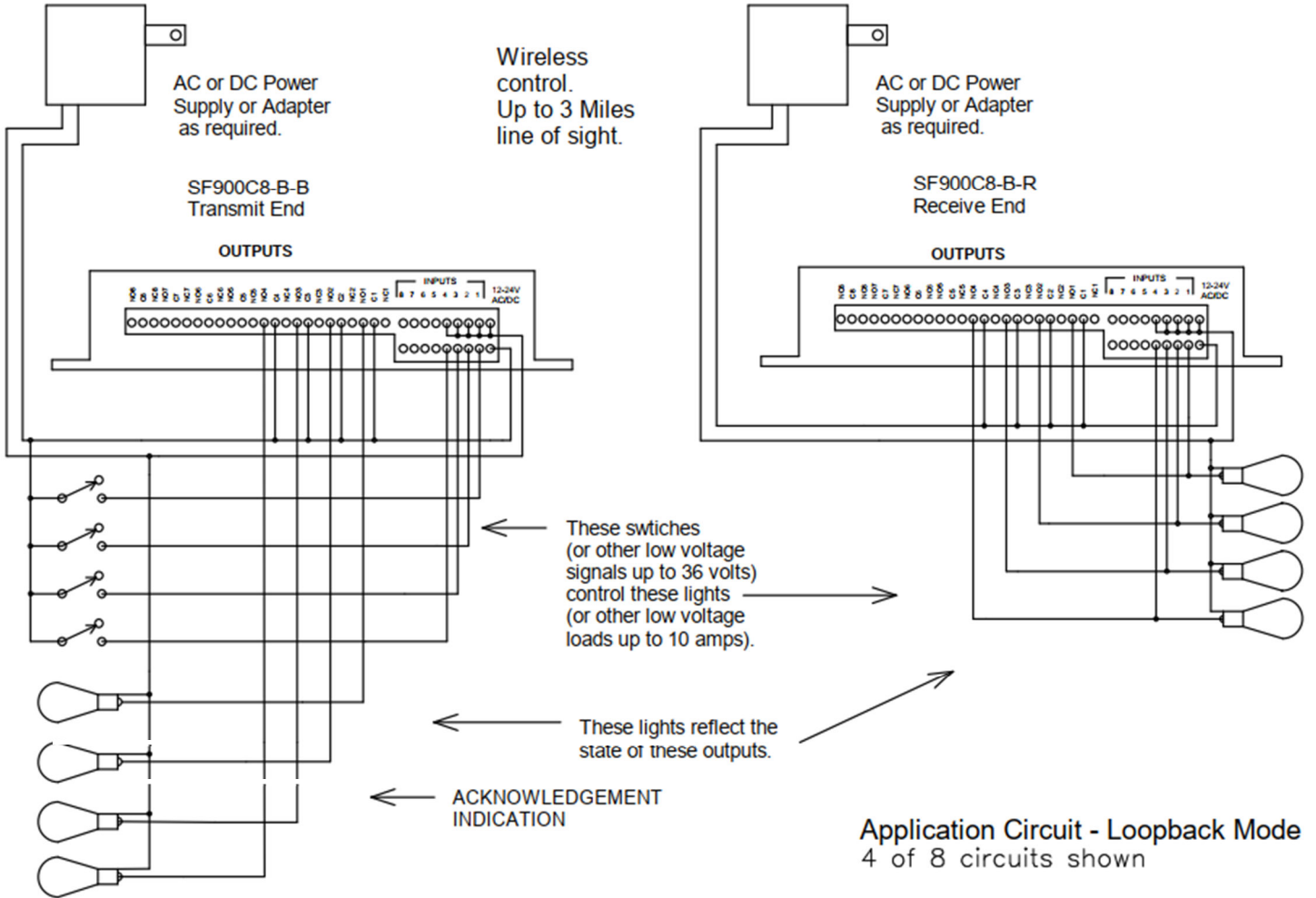

APPLICATION DIAGRAM- Thermostat to HVAC

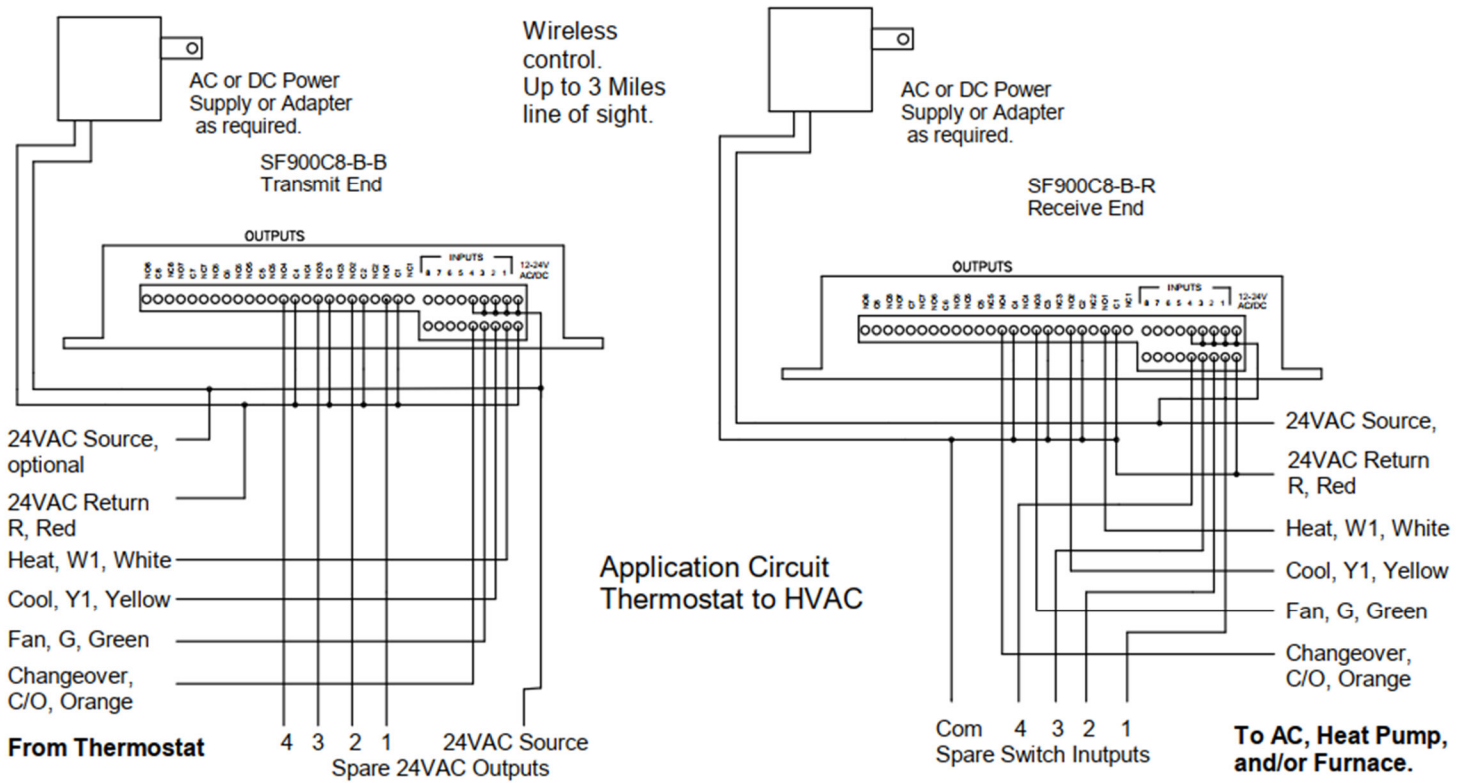

TROUBLESHOOTING GUIDE

Symptom	Possible Problem	Notes
Poor Range	Antenna or Antenna Placement	For omnidirectional operation, the antenna should be vertical and placed in a location clear of obstructions and as high as possible.
	RF Interference	Observe the DATA LED and try a different frequency if necessary.
Doesn't Work	Battery	Always check the battery. With a weak battery it is possible for the SFT900C transmit LED to work without transmissions occurring.
	Data Reception	Check that the DATA LED on the receiver is on bright when the transmitter is transmitting.
	ID Code Match	Transients can sometimes cause a unit to unlearn a code. Redo the Learning process.

ONE YEAR LIMITED WARRANTY (USA)

Products manufactured by APPLIED WIRELESS, INC. (AW) and sold to purchasers in the USA are warranted by AW according to the following terms and conditions. You should read this Warranty thoroughly.

- **WHAT IS COVERED, AND DURATION OF COVERAGE:**

AW warrants the product to be free from defects in materials and workmanship for one (1) year from the date of purchase by the original end user purchaser.

- **WHAT IS NOT COVERED:**

This warranty does not apply to the following:

- Damage caused by accident, physical or electrical misuse or abuse, improper installation, failure to follow instructions contained in the User's Guide, any use contrary to the product's intended function, unauthorized service or alteration (i.e. service or alteration by anyone other than AW).
- Damage occurring during shipment.
- Damage caused by acts of God, including without limitation: earthquake, fire, flood, storms, or other acts of nature.
- Damage or malfunction caused by the intrusion of moisture or other contamination within the product.
- Batteries supplied by AW in or for the product.
- Cosmetic deterioration of chassis, cases, or pushbuttons resulting from wear and tear typical of normal use.
- Any cost or expense related to trouble-shooting to determine whether a malfunction is due to a defect in the product itself, in the installation, or any combination thereof.
- Any cost or expense related to repairing or correcting the installation of an AW product.
- Any cost or expense related to the removal or reinstallation of the product.
- Any product whose serial number or date code is altered, defaced, obliterated, destroyed, or removed.

This warranty is extended to the original purchaser of the product(s) only, and is not transferable to any subsequent owner or owners of the product(s). AW reserves the right to make changes or improvements in its products without incurring any obligation to similarly alter products previously purchased.

- **EXCLUSION OF INCIDENTAL OR CONSEQUENTIAL DAMAGES:**

AW expressly disclaims liability for incidental and consequential damages caused (or allegedly caused) by the product. The term "incidental or consequential damages" refers (but is not limited) to:

1. Expenses of transporting the product to AW to obtain service.
2. Loss of use of the product.
3. Loss of the original purchaser's time.

- **LIMITATION OF IMPLIED WARRANTIES:**

This warranty limits AW's liability to the repair or replacement of the product. AW makes no express warranty of merchantability or fitness for use. Any implied warranties, including fitness for use and merchantability, are limited in duration to the period of the one (1) year express limited warranty set forth herein. The remedies provided under this warranty are exclusive and in lieu of all others. AW neither assumes nor authorizes any person or organization to make any warranties or assume any liability in connection with the sale, installation, or use of this product.

Some states do not allow limitations on how long an implied warranty lasts, and some states do not allow the exclusion or limitation of liability for incidental or consequential damages so the limitations or exclusions stated herein may not apply to you. This warranty gives you specific legal rights and you may have other rights which vary from state to state.

- **HOW TO OBTAIN WARRANTY SERVICE:**

If a product covered by this warranty and sold in the USA by AW proves to be defective during the warranty period AW will, at its sole option, repair it or replace it with a comparable new or reconditioned product without charge for parts and labor, when said product is returned in compliance with the following requirements:

1. You must first contact AW at the following address/phone for assistance:

APPLIED WIRELESS, INC.
1250 Avenida Acaso, Suite F
Camarillo, CA 93012
Phone: (805) 383-9600

If you are instructed to return your product directly to the factory, a Return Merchandise Authorization number (RMA) will be issued to you.

2. You must package the product carefully and ship it insured and prepaid. The RMA number must be clearly indicated on the outside of the shipping container. *Any product returned without an RMA number will be refused delivery.*
3. In order for AW to perform service under warranty, you must include the following:
 1. Your name, return shipping address (not a PO Box), and daytime telephone number.
 2. Proof of purchase showing the date of purchase.
 3. A detailed description of the defect or problem.

Upon completion of service, AW will ship the product to the specified return shipping address. The method of shipping shall be at AW's sole discretion. The cost of return shipping (within USA) shall be borne by AW.



Applied Wireless products are designed and manufactured with pride in the United States of America

© Copyright 2017 by Applied Wireless, Inc. All rights reserved.
Specifications subject to change without notice.

APPLIED WIRELESS, INC.
1250 Avenida Acaso, Ste. F Camarillo, CA 93012
Phone: 805-383-9600 Fax: 805-383-9001
Email: sales@appliedwireless.com
www.appliedwireless.com